

Fast Brake Rectifier (GPE & GPU) Installation and Maintenance Instructions

BIM 1095



Retain These Safety Instructions For Future Use

Fast Rectifier (GPE & GPU) – Brake Option

The “GP...” type rectifiers provide improved brake performance in both brake release time and stopping time. The **GP** is a two-stage “push” design that uses both full-wave and half-wave rectifier operation; when power is first applied, it operates as a full-wave rectifier for approximately 250ms, after which it operates as a half-wave rectifier.

There are two ways to apply **GP** rectifiers. In the first method, known as “**Overexcitation**,” the brake is released very quickly. In the second method, known as “**Reduced Power Holding**,” the brake is set very quickly, allowing for very fast stopping times.

There are two types of “GP...” rectifiers.

GPE – “External DC-Switching”

- Designed for external control of the brake’s DC-switching.
- Primarily used in across-the-line applications where the brake power is supplied by the motor terminals.

GPU – “Integrated DC-Switching / Voltage Sensing”

- This type of rectifier is primarily used when the brake is powered separately from the motor.
- Includes applications involving two-speed motors, motors powered by an inverter or soft-starter.



Overexcitation (fast brake release)

In overexcitation the rectifier initially over-voltages the brake coil. This overexcitation of the rectifier produces a magnetic field in the brake coil that is stronger than normal, releasing the brake much more quickly. The

rectifier is then switched over to a lower holding voltage so as not to thermally overload the brake coil. In this method the brake coil is selected as if the brake system is powered by a half-wave rectifier. Therefore, the brake coil’s DC-voltage rating should be 45% of the AC voltage applied to the rectifier. This type of brake control is also called “Voltage Forcing” and “Supercharging.”

Example

System voltage:	230VAC
Brake coil:	105VDC
Initial brake release voltage:	205VDC
Holding brake voltage:	105VDC

This is commonly used in very high cycling brakemotor applications to reduce motor heating during motor start and brake release.

In this method the brake stopping times will be the same as for the standard full-wave or half-wave methods.

Reduced Power Holding (very fast brake stop)

In reduced power holding, the rectifier initially supplies the rated DC voltage to the brake coil. When voltage is first applied, the rectifier operates as a full-wave rectifier (90% of the applied AC voltage), releasing the brake in the standard time. After the brake is released, the rectifier switches to half-wave mode (45% of the applied DC voltage), weakening the brake’s magnetic field. The weaker field will allow the brake to stop more quickly when power is removed. In this method the brake coil is selected as if the brake system is powered by a full-wave rectifier. Therefore, the brake coil’s DC-voltage rating should be 90% of the AC voltage applied to the rectifier.

Example

System voltage:	230VAC
Brake coil:	205VDC
Initial brake release voltage:	205VDC
Holding brake voltage:	105VDC

DC-Switching Fast Brake Engagement (stopping)

The **GP** brake rectifier can also be wired for faster stopping. This method is called DC switching. DC switching directly interrupts the current flow in the rectifier’s DC circuit and provides much faster stopping.

DC Switching is essential for hoisting or lifting applications.

GPE - External DC-Switching

Type	Part #	Input Voltage	Current	
			at 45C	at 75C
GPE20L	19140230	200 – 275 VAC ± 10%	0.7 A	0.5 A
GPE40L	19140240	380 – 480 VAC ± 10%	0.7 A	0.5 A

To implement DC switching, a contact must be installed in between terminals 3 and 4 on the brake rectifier in place of the factory-installed jumper. This switch must close when power is supplied to the rectifier (terminals 1 and 2), and open when power is removed. The IR relay can be used in place of the external switch between terminals 3 and 4, and provides automatic DC switching once power is removed from the motor. However, since it is based on motor current, the IR relay can only be used under two conditions: when the motor is directly powered across the line, and when the brake power is provided via the motor's power terminal.

The contact between terminals 3 & 4 must be capable of switching inductive loads, and/or be IEC AC3 rated.

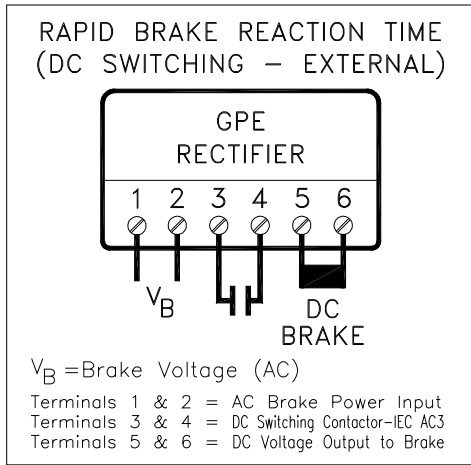

GPU - Integrated DC-Switching – Voltage Sensing

Type	Part #	Input Voltage	Current	
			at 45C	at 75C
GPU20L	19140090	200 – 275 VAC ± 10%	0.7 A	0.5 A
GPU40L	19140170	380 – 480 VAC ± 10%	0.7 A	0.5 A

These GPU rectifiers integrate DC-Switching, which is triggered by sensing the AC voltage supplied to the rectifier. When no voltage is present the rectifier automatically opens the DC circuit. Note: It is not preferred to use the motor terminal block to supply the brake rectifier's AC power due to the motor's slow energy dissipation when switched off.

This type of GP rectifier is primarily designed for use with a separate brake power source, such as inverter-powered motors, soft-start motors, and two-speed motors.

The DC-switching function of the brake rectifier can be disabled by shorting terminals 3 & 4 via a jumper or an external switch.

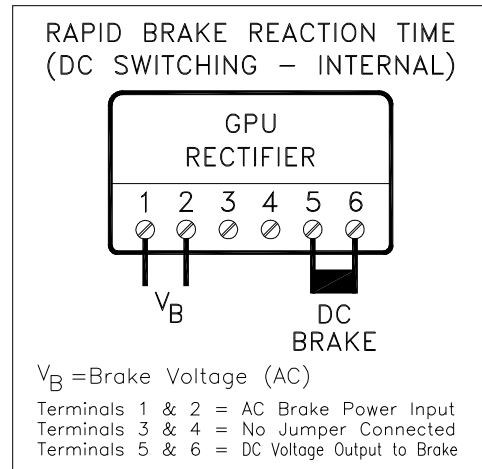

Selection

Overexcitation – Fast Release

AC Brake Supply	Rectifier Part #	Brake Coil
GPE - External DC-Switching		
230VAC	GPE20L - 19140230	105VDC
380VAC	GPE40L - 19140240	180VDC
400VAC	GPE40L - 19140240	180VDC
460VAC	GPE40L - 19140240	205VDC
500VAC	GPE40L - 19140240	225VDC
GPU - Integrated DC-Switching – Voltage Sensing		
230VAC	GPU20L - 19140090	105VDC
380VAC	GPU40L - 19140170	180VDC
400VAC	GPU40L - 19140170	180VDC
460VAC	GPU40L - 19140170	205VDC
500VAC	GPU40L - 19140170	225VDC

Reduced Power Holding – Fast Stopping

AC Brake Supply	Rectifier Part #	Brake Coil
GPE - External DC-Switching		
200VAC	GPE20L - 19140230	180VDC
230VAC	GPE20L - 19140230	205VDC
GPU - Integrated DC-Switching – Voltage Sensing		
200VAC	GPU20L - 19140090	180VDC
230VAC	GPU20L - 19140090	205VDC

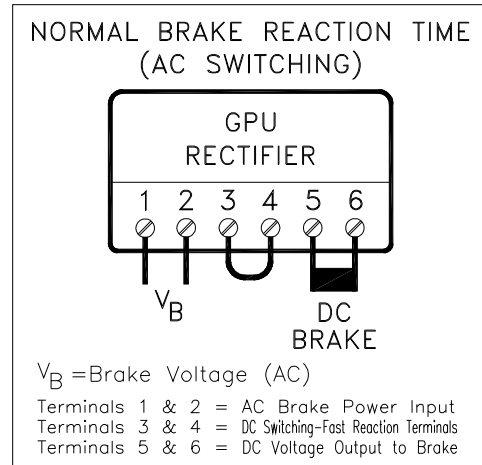

Dimensions

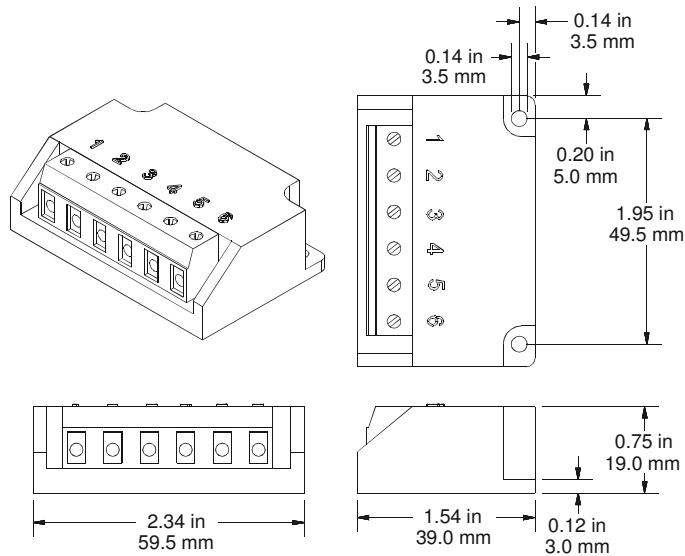

Modes of Operation

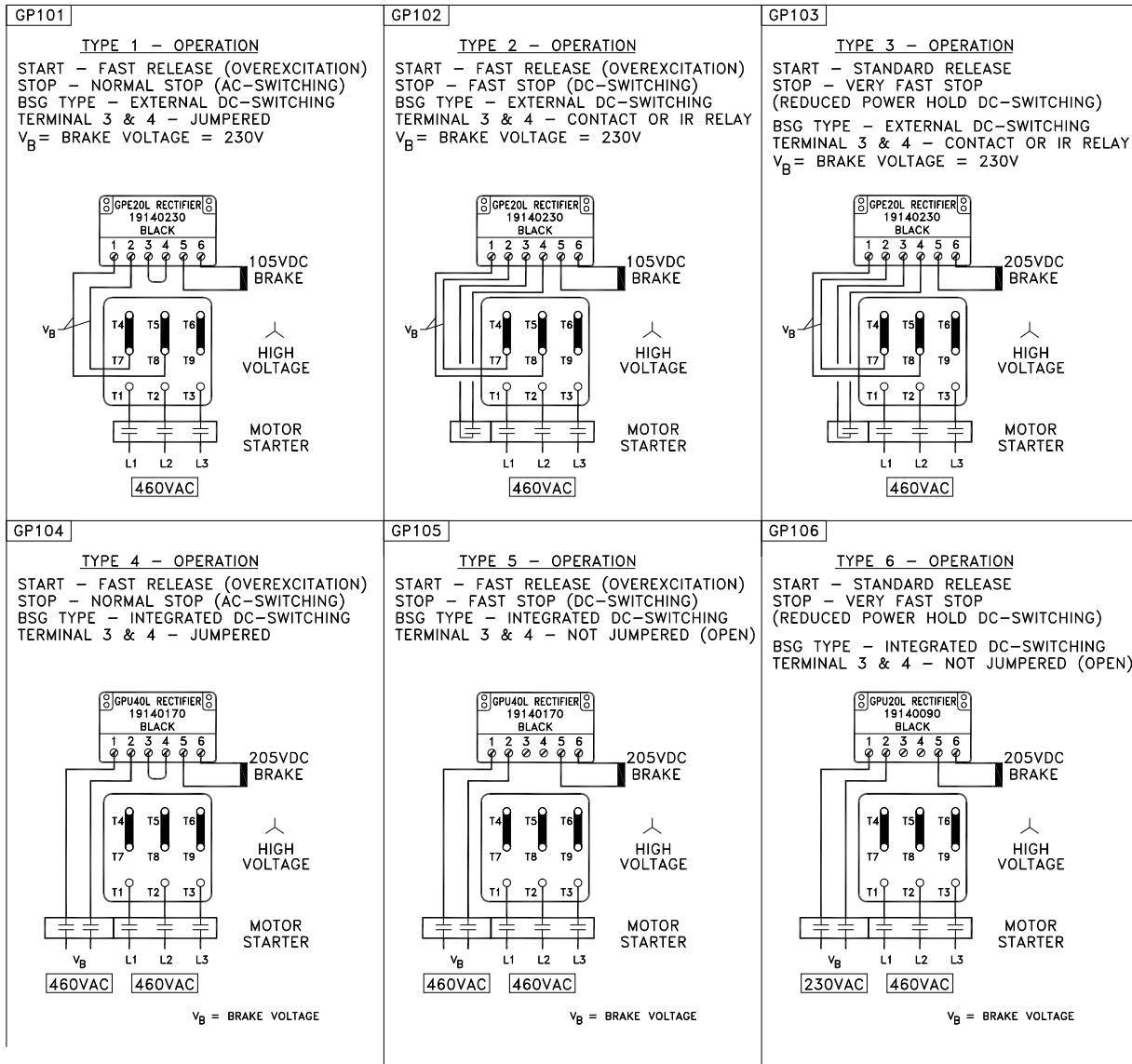

NOTES

NORD Gear Corporation

National Customer Service Toll Free 888-314-6673

www.nord.com

NORD Gear Limited

Toll Free in Canada 800-668-4378

WEST

1137 W. Bradford Circle
Corona, CA 92882
Phone 951-279-2600
Fax 888-408-6673

MIDWEST

PO Box 367
800 Nord Drive
Waunakee, WI 53597
Phone 608-849-7300
Fax 800-373-6673

SOUTH

100 Forsyth Hall Dr.
Building 100B
Charlotte, NC 28273
Phone 704-529-1255
Fax 888-259-6673

CANADA

41 West Drive
Brampton, Ontario L6T 4A1
Phone 905-796-3606
Fax 905-796-8130