



TITAN™ ADJUSTABLE SPEED DRIVES



1. Basic operation and speed adjustment

	WARNING	
Lock-out power before any maintenance is performed. Make absolutely sure that no voltage is applied while work is being done on the drive unit.		

Titan™ Adjustable-Speed Drives are ideal for use when operating conditions dictate infinitely variable output speeds over a fixed range. The Titan™ Drive consists of a motor, belt casing, and main gear drive.

The beltbox contains an Adjusting Pulley (Driver) that is attached to the motor output shaft. A handwheel or optional Electric Remote Control Motor (EMFST) is used to vary the operating pitch diameters of the driver pulley in-turn making a corresponding adjustment to the Spring Pulley (Driven). Belt center distance remains fixed. Speed is typically adjusted by loosening the lock nut handle on the handwheel.

Pulleys are manufactured from the corrosive resistant and extremely durable alloy "Durfondal" to provide superior wear resistance and assure grooving and wear will be minimized under rated operating conditions. All sliding components are coated to resist fretting and corrosion. Pulleys are permanently grease lubricated and require no service during the normal life of the Titan™ drive.

	WARNING	
NORD does not support the use of the Titan™ belt drive in explosion proof or hazardous environments. While the belt is non-sparking, the Titan™ belt drive assembly does not have a safety to disengage the belt. In the event of an overload the belt can slip and generate excessive heat.		

	HARMFUL SITUATION	
Operational speed adjustments must be performed when the motor is operational. Failure to comply may damage the belt and pulleys.		

	IMPORTANT NOTE	
<ul style="list-style-type: none"> • In order to renew the grease coating over the full tracking distance of the pulleys and to avoid damage to the pulley surfaces and/or belt, the Titan™ belt drive should occasionally be operated over the entire speed range. • Speeds stops located on the adjustment spindle are factory adjusted; further adjustments can cause damage to the belt box and/or main drive. • When operating in extremely dusty or dirt environments, an air filter must be installed to the main housing vents to protect the V-belt, pulleys, and coated shafts. • When operating in areas of higher ambient temps, or when installed where ventilation is poor, additional cooling may need to be applied to the belt housing. • The adjustment wheel and speed adjustment shaft should also be cleaned periodically and coated with molybdenum based anti-seize compound. 		

2. Motor

	WARNING	
To prevent possible injury and/or damage to the electric motor, the variable speed drive, or the driven equipment, it is important to follow the motor manufacturer's instructions pertaining to safe handling, installation, and maintenance of the electric motor.		

Connect the motor in accordance with the wiring information supplied by the motor manufacturer and make sure the motor nameplate voltage and frequency agree with the available power supply. Use the proper protective motor switches to help protect the motor windings from overload and/or phase failure.

To insure the same performance the replacement motor must be of the same design and style as the original. The end of the motor shaft must also have a tapped hole in it as shown below.

NEMA Frame Size	Thread Size	Minimum Thread Depth
56C	1/4-20	1.00 inch
143TC/145TC	1/4-20	1.00 inch
182TC/184TC	3/8-16	1.25 inch
213TC/215TC	5/8-11	1.25 inch
254TC/256TC	5/8-11	1.50 inch
284TC	5/8-11	1.50 inch



TITAN™ ADJUSTABLE SPEED DRIVES



3. Installation

Titan™ drive packages may be supplied with a variety of gear units including foot-mounted, flange-mounted or shaft-mounted options.

When selecting the drive installation site, one should remember that air-cooled motors are ideally designed for ambient temperatures between -4°F and +104°F (-20°C and +40°C) and for installation at altitudes of 3,300ft (1,000m) above mean sea level.

The installation site should also ensure the following:

- Unrestricted airflow over the motor and variable speed drive.
- Accessibility to the oil fill-hole, level-hole and vent-hole locations on the main gear drive.
- A foundation (mounting base) of adequate size that is flat, torsionally rigid, and vibration-proof.
- Adequate shaft alignment between the drive and the driven equipment.
- Adequate space to allow motor removal and/or maintenance.
- In cases where brake motors are used, fan guard removal may be necessary to allow for brake adjustment and maintenance.

4.V-Belt replacement

Please reference the general parts lists starting on Page 6 of this manual.

- Run the Titan™ drive to its maximum speed and switch off. Be certain the power can not be inadvertently switched on again.
- Unscrew the socket head screws (521) and remove the belt casing cover, together with the entire speed control unit.
- Remove the old V-belt by first drawing it over the cones of the spring-loaded pulley (507) and then sliding over the open adjustable pulley (506). Installing a tapered wedge made of soft pine between the spring pulley halves will help keep the adjustable pulley open, and may aid in the removal of the old V-belt.
- Wrap the new V-belt around the cones of the open adjustable pulley (506) and then draw it over the spring-loaded pulley (507). Installing a tapered wedge made of soft pine between the spring pulley halves will help keep the adjustable pulley open, and may aid in the installation of the new V-belt.
- Reassemble the belt casing cover.

	WARNING	
<p>NORD does not support the use of the Titan™ belt drive in explosion proof or hazardous environments. While the belt is non-sparking, the Titan™ belt drive assembly does not have a safety to disengage the belt. In the event of an overload the belt can slip and generate excessive heat.</p>		

TITAN™ V-Belt part numbers and sizes

TYPE	Belt P/N	Belt Size
R100	71092000	22 x 7 x 567 x 28°
R150	71592000	28 x 8 x 754 x 28°
R196	71992000	33 x 9 x 906 x 28°
R210	72192000	37 x 10 x 954 x 28°
R250	72592000	47 x 12 x 1135 x 28°
R280	72892100	55 x 15 x 1255 x 28°
R300	73092100	51 x 16 x 1444 x 28°
R350	73592100	70 x 18 x 1515 x 30°
R375	73792100	83 x 23 x 1767 x 32°
R400	74092100	83 x 23 x 1842 x 32°
R500	75092100	83 x 26 x 2877 x 32°

5. Pulley replacement

STOP
HARMFUL SITUATION
STOP

- Install new pulleys in the same exact orientation as the old pulleys to prevent damage to the machinery.
- Special care must be taken when reassembling the Z-Flow pattern, as the moving parts of the pulleys must always be situated on opposite (diagonal) sides.
- Do not attempt to disassemble spring pulley. Failure to remove the spring without the proper fixtures/tools can result in serious injury.

Please reference the instructions and diagrams shown below, as well as the general parts lists that start on Page 6 of this manual.

- The spring loaded pulley (507) and the adjustable pulley (506) are held securely to the shaft using a holding screw (519/516), a thrust washer (518/515), and a snap ring (520/517). Remove the screw (519/516), thrust washer (518/515) and snap ring (520/517) that are used to hold the pulley on the shaft.
- In order to protect the tapped hole in the shaft, place a steel disc (I), slightly smaller than the shaft diameter, against the end of the shaft.
- The thrust washer has an internal thread diameter that is slightly larger than the thread on the holding screw (516/519). Refit the snap ring (520/517) and replace the thrust washer (518/515). In order to aid in the removal of the pulley, a disassembly screw, slightly larger than the holding screw (516/519) can be inserted into the thrust washer (518/515) and tightened against the steel disc (I). Remove the spring loaded pulley (507) or the adjustable pulley (506) by using the thrust washer and disassembly screw (III) as a "jacking bolt".
- If the thrust washer (518/515) rotates when trying to remove the pulley, secure the thrust washer with a pin inserted into the keyway (II).
- After the old pulley is removed, disassemble or remove the disassembly screw (III), thrust washer (518/515), snap ring (520/517), and protective steel disc (I) that was placed over the shaft.
- Before installing the new pulley, apply an anti-seize compound to the shaft. Reassemble the snap ring (520/517) and thrust washer (518/515) into the pulley bore. Use the holding screw (519/516), pull the pulley onto the shaft. Do not drive the pulley onto the shaft with a hammer.

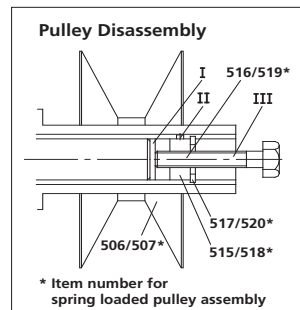
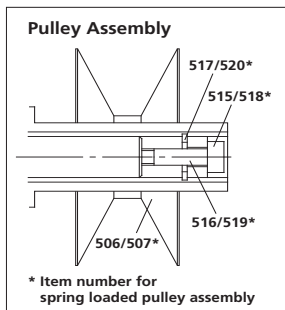

6. Electromechanical remote control speed adjustment

The Electromechanical Remote Control (EMFST) replaces the hand wheel when remote speed adjustment is desired. With the EMFST the speed range is set by adjusting the limit switches that are supplied with the motor. The limit switches are factory preset to operate within the specified speed range of the Titan™ variator.

STOP
HARMFUL SITUATION
STOP

The EMFST is assembled to the control-side of the Titan™ belt case; prior to assembly, the adjustment cone of the EMFST control must be driven towards the "full-back" or "minimum speed" position. This must be done by powering the EMFST motor. To prevent damage to the adjustment spindle, nut, or EMFST gear unit, one must be very careful to stop the motor prior to reaching the final "full-back" position.

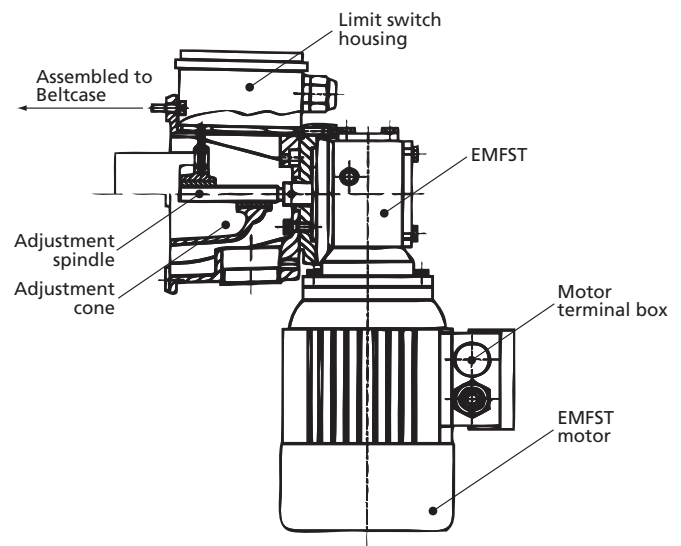

Dual Rated – Electronic Remote Control Motor Option (EMFST)

Type	FY63 A-4
Phase	3 ~
Nominal Frequency	50 / 60 Hz
Nominal Power	0.12/0.14 kW
Nominal Speed	1360 / 1660
Voltage	265Δ - 460Y/230Δ - 400Y
Current at High Voltage	0.43/0.50 Amp
Starting Current Ratio	3.5
Starting Torque Ratio	1.8
Breakdown Torque Ratio	1.9
Efficiency	45.2%
Power Factor	0.68/0.70
Enclosure	IP55
Insulation Class/Rise	F/B
Weight	4.0 kg or 8.82 lb



TITAN™ ADJUSTABLE SPEED DRIVES



DRIVESYSTEMS

RETAIN FOR FUTURE USE

U21005 - 4 of 8

7. Wiring diagram

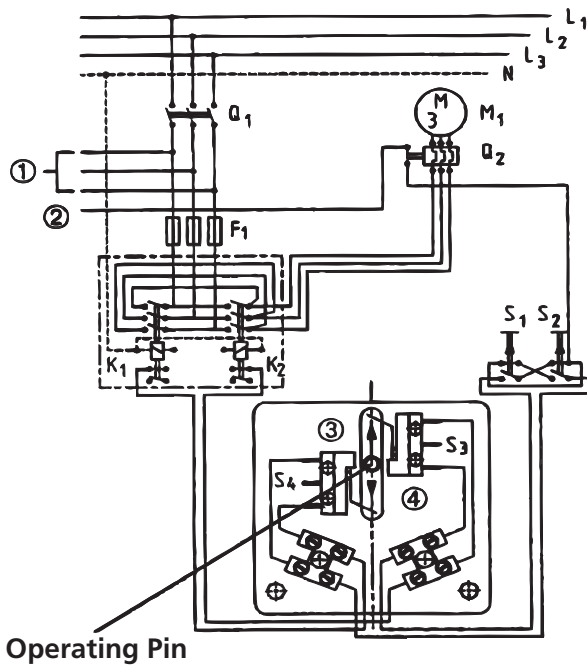

Symbol legend - wiring diagram

L ₁ , L ₂ , L ₃	Incoming Power
K ₁ , K ₂	Combined relay for phase reversal of the EMFST motor (CW or CCW shaft rotation)
M ₁	EMFST motor
Q ₁	Main switch
Q ₂	Motor protection switch
S ₁	Push Button "speed increase"
S ₂	Push Button "speed decrease"
S ₃	Limit switch "upper limit"
S ₄	Limit switch "lower limit"
①	Main drive motor
②	Control for servo motor and motor protection switch
③	Direction of "speed increase"
④	Direction of "speed decrease"

△
low voltage

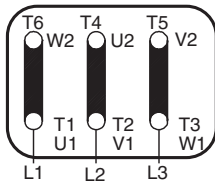

Λ
high voltage

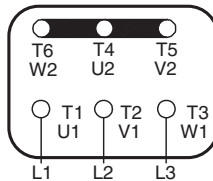

8. Limit switch adjustment



HARMFUL SITUATION



The main motor and Titan™ variator must be operating while trying to adjust the limit switches of the EMFST motor.

- Wire the EMFST motor according to the motor wiring diagram (Page 4).
- Open the cover plate of the limit switch housing and check the direction of rotation while in operation as follows:
 - Pressing Push Button S₁ should move the operating pin forward or towards the belt case.
 - Pressing Push Button S₂ should move the operating pin in the opposite direction or away from the belt case.
 - If the direction of rotation is incorrect, reverse the polarity of the electric remote control motor (EMFST).
- Check the function of the limit switches as follows:
 - Actuate Limit Switch S₃ (upper speed limit) and press Push Button S₁ (speed increase).
 - Actuate Limit Switch S₄ (lower speed limit) and press Push Button S₂ (speed decrease).
 - In both cases there should be no movement of the operating pin.
- Operate the EMFST motor towards minimum speed. Use a tachometer to check the final output speed of the drive unit. As minimum speed is approached, make only small incremental adjustments in speed. Re-check the output speed of the drive unit.
- Upon reaching the required minimum speed, stop the EMFST unit.



IMPORTANT NOTE



There should be no "wheezing" noise emitted from the belt drive at this stage. If there is such a noise the belt may be "bottoming" on the "adjustable control pulley". You should then increase the speed of the drive slightly.



TITAN™ ADJUSTABLE SPEED DRIVES



DRIVESYSTEMS

RETAIN FOR FUTURE USE

U21005 - 5 of 8

8. Limit switch adjustment (ctd)

- F. Unscrew the two fixing screws of the minimum speed limit switch. Adjust the limit switch by putting it against the operating pin and re-tightening the screws.
- G. Operate the EMFST motor towards maximum speed. Use a tachometer to check the final output speed of the drive unit. As maximum speed is approached, make only small incremental adjustments in speed. Re-check the output speed of the drive unit.
- H. Upon reaching the required maximum speed, stop the EMFST unit.

IMPORTANT NOTE

There should be no "wheezing" noise emitted from the belt drive at this stage. If there is such a noise the belt may be bottoming on the "spring pulley". You should then decrease the speed of the drive slightly.

- I. Unscrew the two fixing screws of the maximum speed limit switch. Adjust the limit switch by putting it against the operating pin and re-tightening the screws.
- J. Re-check both minimum and maximum speed positions by operating the EMFST and moving towards the limit switch settings. Use a tachometer to check the speed range at the output of the final drive. Readjust limit switches if necessary.

9. Non-contacting speed indicator

IMPORTANT NOTE

The speed indicator options are not available when using the EMFST.

The speed indicator contains a built in sensor which converts the signals coming from the pulse generator into a direct current signal for the speed indicator. Adjustment of the analog style meter is possible by means of set screws on the back of the meter.

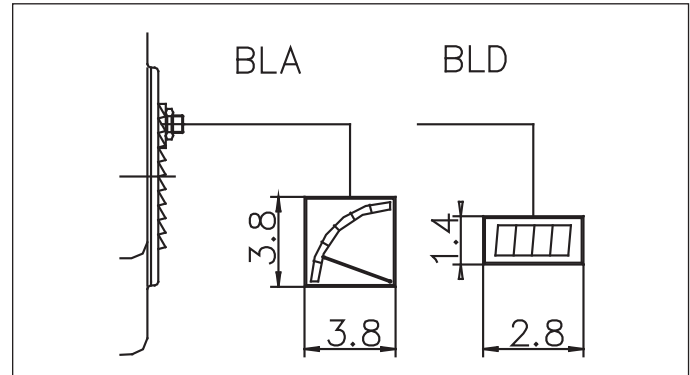

Type BLA: analog speed indicator

Scale Marking: 0-100% - Scale deflection: 90°
Type of enclosure: IP 53 – Terminals IP 00

Type BLD: digital speed indicator

Digital indicator: 4 digits – 7 segment red LED display.
Type of enclosure: IP 50 – Terminals IP 00.



TITAN™ ADJUSTABLE SPEED DRIVES



DRIVESYSTEMS

RETAIN FOR FUTURE USE

U21005 - 6 of 8

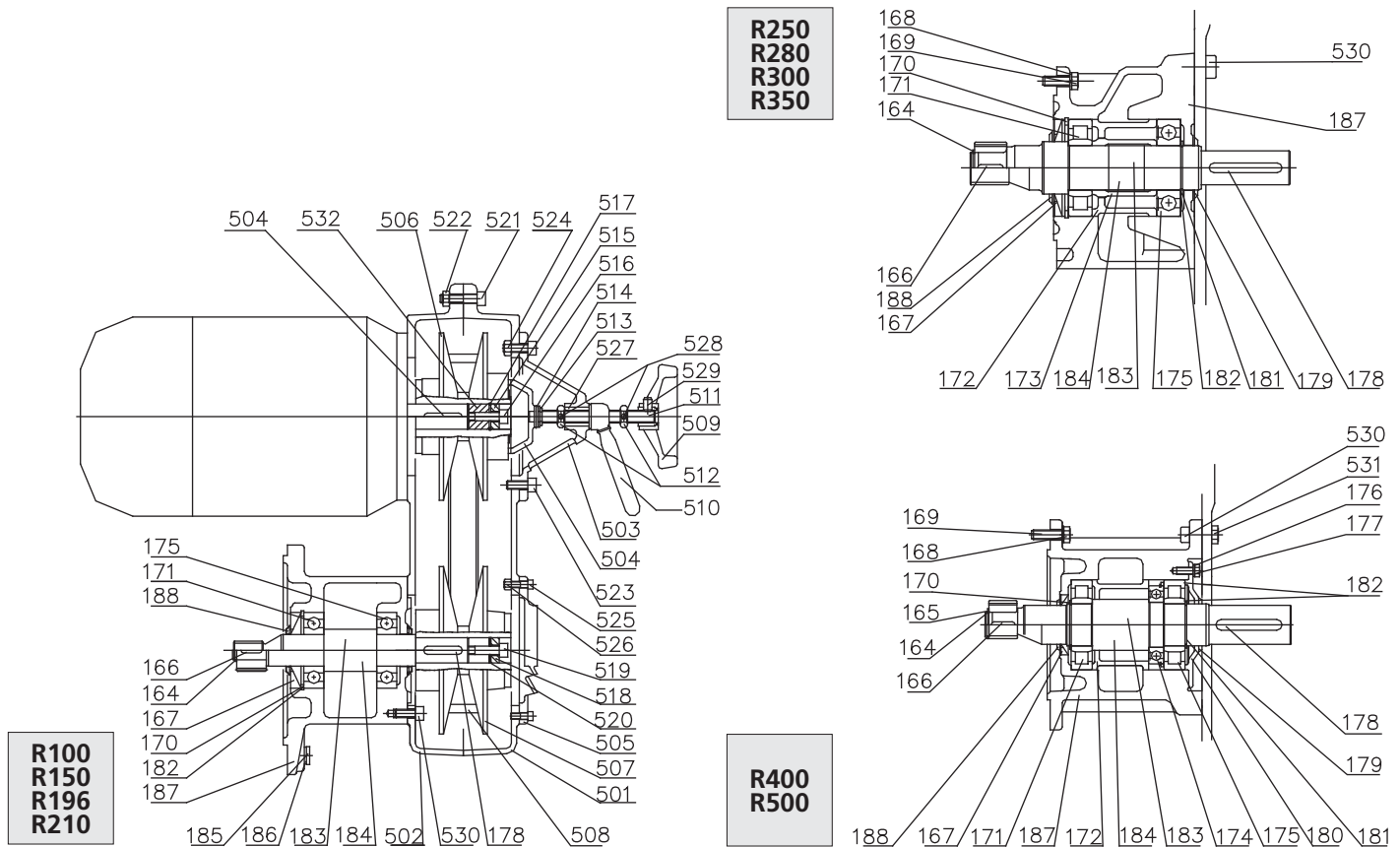

TITAN™ General Parts List

164	Circlip / Snap ring	184	Input shaft, cut gear	515	Thrust Washer
165	Shim	185	Locking screw	516	Socket head bolt
166	Key	186	Seal washer	517	Circlip / Snap ring
167	Shaft Seal	187	Reducer input housing	518	Thrust washer
168	Washer	188	Oil slinger	519	Socket head bolt
169	Hex head bolt	501	Beltcase cover	520	Circlip / Snap ring
170	Circlip / Snap ring	502	Beltcase connecting cover	521	Socket head bolt
171	Input shaft bearing	503	Hand wheel adjustment cover	522	Hex nut
172	Spacer	504	Adjustment cone	523	Socket head bolt
173	Spacer	505	Ventilation cover	524	Hex nut
174	Ball bearing	506	Adjustable pulley	525	Socket head bolt
175	Input shaft bearing	507	Spring loaded pulley	526	Hex nut
177	Hex head bolt	508	V-belt	527	Screw bushing
178	Key	509	Handwheel	528	Set screw
179	Oil slinger	510	Locking Handle	529	Set screw
180	Bearing cover	511	Adjustment Spindle	530	Socket head bolt
181	Circlip / Snap ring	512	Locknut (speed stop)	531	Hex nut
182	Shim	513	Washer	532	Spacer
183	Input shaft, plain	514	Spiral Pin / Spring Cotter		

NORD Gear Limited
Toll Free in Canada: 800.668.4378

NORD Gear Corporation
Toll Free in the United States: 888.314.6673

**Angular Handwheel Assembly
for R100-R400**

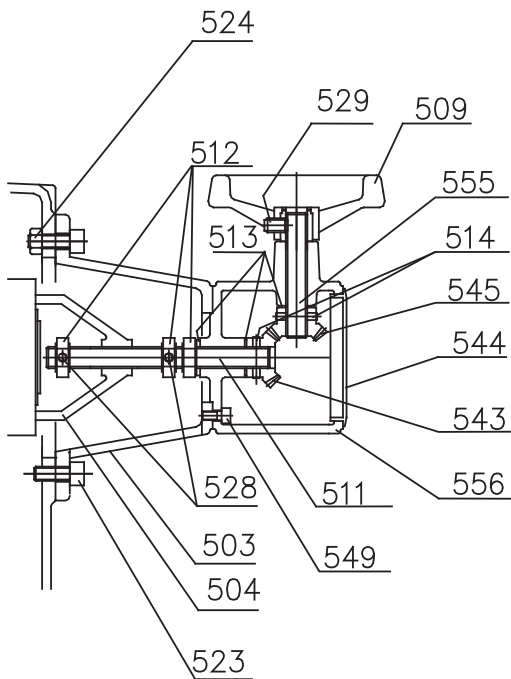

**Non-Contacting Speed Indicator
for R100-R500 ***

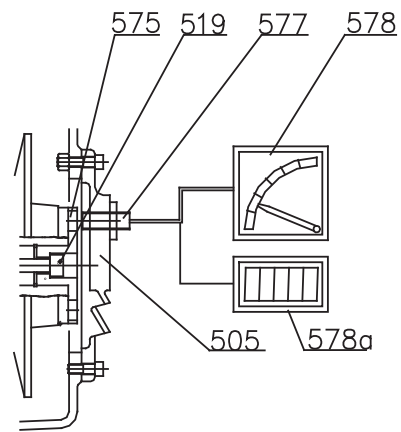

Angular Handwheel Assembly & Non-contacting Speed Indicator

503	Adjustment Cover	519*	Socket head bolt	549	Socket head bolt
504	Adjusting Cone	523	Socket head bolt	555	Handwheel shaft
505*	Ventilation Cover	524	Hex nut	556	Bevel gear case
509	Handwheel	528	Set screw	575*	Pulse generator
511	Adjustment Spindle	529	Set screw	577*	Pulse Sensor
512	Locknut	543	Bevel Gear	578*	Speed Indicator (Type BLD)
513	Washer	544	Seal plug	578a*	Speed Indicator (Type BLD)
514	Spiral Pin / Spring Cotter	545	Bevel gear		



TITAN™ ADJUSTABLE SPEED DRIVES



11. TITAN™ Belt replacement part numbers

Ttan™ Type	Belt P/N	Belt Size
R100	71092000	22 x 7 x 567 x 28°
R150	71592000	28 x 8 x 754 x 28°
R196	71992000	33 x 9 x 906 x 28°
R210	72192000	37 x 10 x 954 x 28°
R250	72592000	47 x 12 x 1135 x 28°
R280	72892100	55 x 15 x 1255 x 28°
R300	73092100	51 x 16 x 1444 x 28°
R350	73592100	70 x 18 x 1515 x 30°
R375	73792100	83 x 23 x 1767 x 32°
R400	74092100	83 x 23 x 1842 x 32°
R500	75092100	83 x 26 x 2877 x 32°

12. TROUBLESHOOTING

Problem with Variable Speed Unit	Possible Causes	Suggested Remedy
Drive Slips	V-Belt is worn	Replace V-Belt.
	V-Belt or face of adjustment pulley is dirty or contaminated.	Clean Contaminated part: <ul style="list-style-type: none"> • V-Belt – use dry cloth or paper. • Adjustment Pulley – okay to use mild solvent provide excess is cleaned with a dry cloth.
	Load is too high.	Check measured power and reduce operating load to catalog values.
Drive heats up excessively	Load is too high.	Check measured power and reduce operating load to catalog values.
Drive appears noisy or too loud.	V-Belt is damaged: <ul style="list-style-type: none"> • May be caused after a brief stalling of the drive. • May be caused by intermittent loading of the drive. 	Determine cause of damage, and replace V-Belt.

Problem with Electromechanical Remote Control (EMFST)	Possible Causes	Suggested Remedy
Speed cannot be adjusted.	Unit is not wired properly.	Wire unit in accordance with circuit diagram.
Speed range cannot be reached.	Motor limit switches turn off too early.	Adjust limit switches.