



# NORDISC™ ADJUSTABLE SPEED DRIVES



DRIVESYSTEMS

RETAIN FOR FUTURE USE

U21010 - 1 of 6

## 1. Basic operation and speed adjustment

The NORDISC™ Friction Drive will supply infinite variable speed adjustments over a fixed speed range. The NORDISC™ Drive consists of a motor, dry traction drive, and main gear drive. The motor is typically furnished as an integral mount to the traction drive, however a NEMA C-face Input Adapter (Flex-C-Input Adapter) is also available.

Attached to the output shaft of a constant speed motor, is the driving disc portion of the traction drive. The driven disc is angled approximately 2°, localizing the friction contact on the disc pair. As the adjustment spindle is rotated, the input side of the housing moves either up or down, changing the effective pitch diameter of the driving disc. Speed is typically adjusted by the handwheel.

STOP	<b>HARMFUL SITUATION</b>	STOP
Speed adjustments must be performed when the motor is running to prevent possible damage to the traction drive parts.		

STOP	<b>HARMFUL SITUATION</b>	STOP
Initial adjustments of the speed stops located internal to the traction drive are completed at the factory. Further adjustments of the speed stops can cause damage to the traction drive and/or main drive.		

## 2. NORDISC™ Friction Drive

The variable speed drive requires only minimal maintenance. However, the friction ring is a wear item.

STOP	<b>HARMFUL SITUATION</b>	STOP
The traction drive should be periodically operated through its entire speed range, in order to prevent localized wear patterns on the driving disc and/or possible damage to the driving disc.		

The friction drive does not require lubrication unless it is disassembled for an overhaul. Units should be checked periodically for:

- Increased noise level.
- Increased operating temperatures.
- Increased vibration.
- Increased motor amperage draw.
- Increased or excessive shaft movement.

Every 10,000 hours of operation, it is suggested that the bearings be cleaned and re-greased with a lithium-based NLGI #2 Grease.

The adjustment wheel and speed adjustment shaft should also be cleaned periodically and coated with molybdenum-based anti-seize compound.

## 3. Motor

!	<b>WARNING</b>	!
To prevent possible injury and/or damage to the electric motor, the variable speed drive, or the driven equipment, it is important to follow the motor manufacturer's instructions pertaining to safe handling, installation, and maintenance of the electric motor.		

Connect the motor in accordance with the wiring information supplied by the motor manufacturer and make sure the motor nameplate voltage and frequency agree with the available power supply. Use the proper protective motor switches to help protect the motor windings from overload and/or phase failure.

!	<b>WARNING</b>	!
Explosion proof motors should not be used on the friction drive. The friction drive is not recommended for use in explosion proof atmospheres.		

## 4. Separating the driven disc assembly from the driving disc assembly

- Lockout the electric power to the motor and make sure the wires are disconnected.
- Support the intermediate housing (Item 447) and the attached motor assembly.
- Remove the four hex head screws that connect the driving disc assembly (intermediate housing / Item 447) to the driven disc assembly (output housing / Item 402).
- Slide the intermediate housing (Item 447) away from the output housing (Item 402).

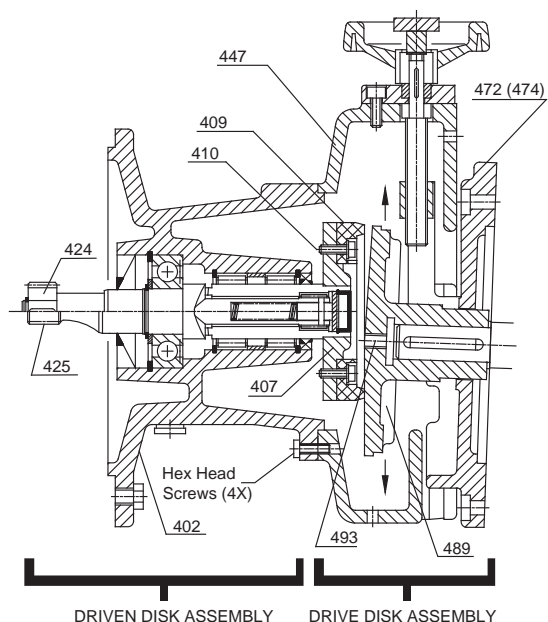



# NORDISC™ ADJUSTABLE SPEED DRIVES



DRIVESYSTEMS

RETAIN FOR FUTURE USE

U21010 - 2 of 6

## 5. Friction disc replacement

- A. Separate the driven disc assembly from the driving disc assembly (See Separate Instructions).
- B. Once the friction disc (Item 409), is exposed remove the socket head cap screws (Item 410) that hold the friction disc or friction ring (Item 409) to the friction disc carrier (Item 407).
- C. Clean the contact surface between the friction disc and friction disc carrier.
- D. Vacuum or brush out the NORDISC™ drive housing to remove accumulated friction material dust. Be careful not to ingest dust while cleaning.
- E. Inspect main housing for damaged parts while disassembled.
- F. Attach the new friction disc to the carrier using the socket head cap screws. Permissible tightening torques are per the table below:

Type	Screw Size	Material Grade	Tightening Torque
RV10	M5 X 12	8.8	6 N-m / 53 lb-in
RV20	M5 X 16	8.8	6 N-m / 53 lb-in
RV30	M6 x 16	8.8	10 N-m / 88 lb-in
RV40	M6 x 20	8.8	10 N-m / 88 lb-in

- G. Re-assemble intermediate housing or "RV" housing (Item 447) to output bearing housing (Item 402). To re-assemble, apply Steps 1-4 in reverse order. Use a thread-locking compound to secure the hex head screws.

## 6. Bearing and seal replacement - NORDISC™ output

- A. Separate the driven disc assembly from the driving disc assembly (See Separate Instructions).
- B. Slide the intermediate housing (Item 447) away from the output housing (Item 402) and remove the shaft oil seal (Item 439).
- C. Remove circlips/snap-rings (Item 437 and 438).
- D. Remove shims and supporting disc (Items 434 & 436).
- E. Slide the hollow shaft/friction disc carrier assembly (Item 404) away from output housing (Item 402).
- F. Press output gear-shaft (Item 424 or 425) and bearing (Item 435) out of output housing. Shaft and bearing come out on the output or gear-shaft side.
- G. Remove oil seal (Item 421) from output housing.
- H. Remove two circlips/snap-rings (Items 418) from output housing and remove needle bearings and spacer (Items 419 and 420).
- I. Re-assemble in the reverse order, replacing ball bearing, needle bearings, and oil seals (Items 435, 419, 421 and 439). If required, also replace any shims, spacers, or circlips (Items 434, 436, 420, 437, 438, and 418). During assembly, repack bearings with a lithium-based NLGI #2 grease. Needle bearing cavity should be approximately 1/3 full after re-greasing.

**WARNING**

- The output shaft compression spring (Item 430) does not require maintenance. If the spring fractures the complete shaft should be replaced as a complete assembly or returned to NORD Gear for repair.
- Special fixtures are required to remove and install the spring. Personal injury can result if this repair is attempted in the field.

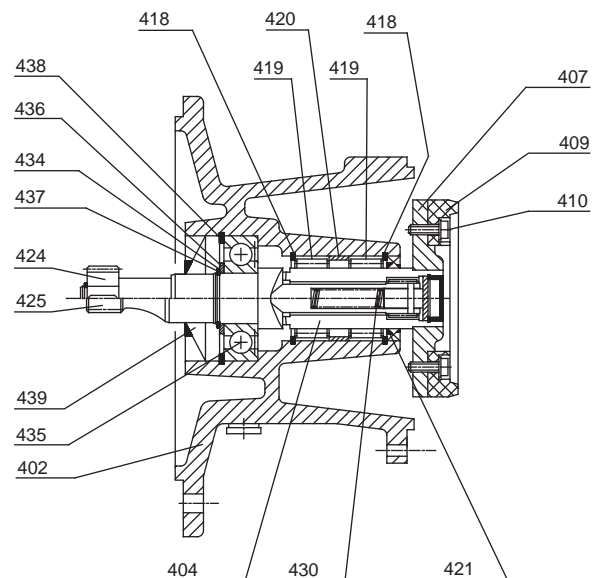



# NORDISC™ ADJUSTABLE SPEED DRIVES



DRIVESYSTEMS

RETAIN FOR FUTURE USE

U21010 - 3 of 6

## 7. Driving disc disassembly and reassembly

The driving disc (Item 489) is attached directly to either the motor shaft or the shaft of the C-Face Input (Flex-C-Input) Adapter. One must first remove the driving disc from the input-side of the NORDISC™ in order to:

- Replace the motor.
- Replace the bearings in the C-Face Adapter.

### Driving Disc Removal

- Separate the driven disc assembly from the driving disc assembly (See Separate Instructions).
- Slide the intermediate housing (Item 447) away from the output housing (Item 402).
- After removing the input side from the output side, position the driving disc (Item 489) in the middle of the housing by turning the speed adjusting hand wheel (Item 462).
- Remove the setscrew in the middle of the driving disc (Item 493). Insert a hardened bolt in the hole that is in the center of the driving disc (Item 489), and tighten the bolt against the shaft to separate or remove the driving disc from the shaft (see table).

Type	Setscrew Size	Bolt Size
RV10	1/4-20	1/4-20 x 2-1/4 in
RV20	5/16-18	5/16-8 x 2-3/4 in
RV30	1/2-13	1/2-13 x 3 in
RV40	5/8-11	5/8-11 x 4 in

### Driving Disc Re-Assembly

- Installation of the driving disc (Item 489) may require heating the disc in an oven or on a hot plate, to allow the disc to be positioned all the way on to the motor shaft or C-Face Input shaft.

	<b>WARNING</b>	
Exercise extreme caution when handling the hot driving disc. Protective gloves are recommended.		

- After heating the disc, position it all the way onto the shaft until it bottoms.
- Using the table below, measure the "X" dimension from the bottom edge of the friction drive housing (Item 447) to the face of the driving disc (Item 489).

Type	Setscrew Size	"X" Dimension
RV10	1/4-20	0.837/0.867 in
RV20	5/16-18	0.975/1.005 in
RV30	1/2-13	1.133/1.163 in
RV40	5/8-11	1.311/1.341 in

- Insert the setscrew (Item 493) into the hole in the center of the driving disc, and tighten the setscrew snug to the shaft of the motor or C-Face input assembly. Use a thread-locking compound to help secure the setscrew.

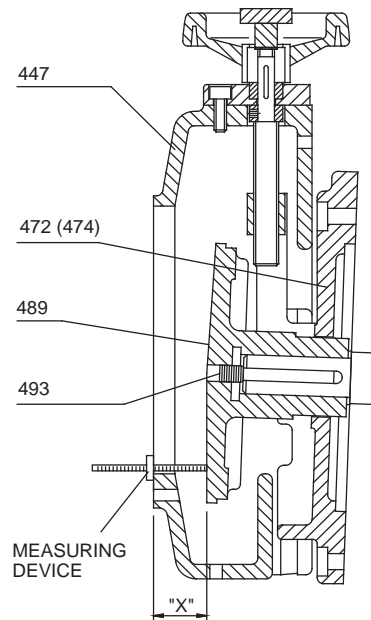

## Removal and re-assembly of motor or C-face input adapter (Flex-C-Input)

- A. Separate the driven disc assembly from the driving disc assembly and remove the driving disc (See Separate Instructions).
- B. After removing the driving disc (Item 489), the mounting bolts for the motor or C-Face adapter can be accessed. To gain access to all four bolts requires the removal of the two cam grooves (Item 477). The cam grooves can be removed by first removing the socket head screws (Item 478). Then, the motor or adapter bolts ((Item 453) can be removed.
- C. Assembly is the reverse of disassembly.

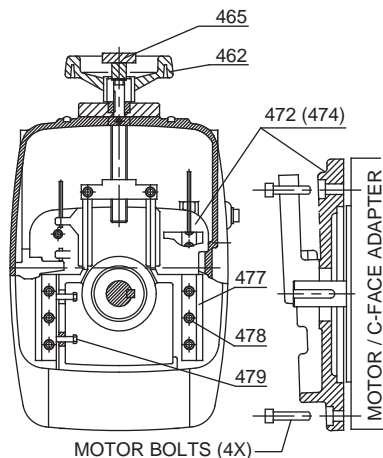

## Cam groove or tapered gib adjustment

The cam groove or tapered gib on the right side (Item 477) is not adjustable. The cam groove on the left-hand side is to be adjusted by the screws (Item 479) located next to the slide bar (Item 477). The cam grooves are properly adjusted when the slide plate (Item 472 or 474) is allowed to move freely through its complete range.

- A. Remove the handwheel assembly nut (Item 465) and handwheel (Item 462) before making adjustment.
- B. Clean sliding surfaces of the slide plate and cam grooves, and then re-apply a molybdenum-based anti-seize compound to these surfaces.
- C. Assemble the motor and/or c-face adapter to the slide plate (Item 472/474) by re-installing the motor bolts. Apply a thread-locking agent to the screw threads during assembly.
- D. Place the non-adjustable (right-side) cam groove onto the slide plate and tighten the socket head setscrews (Item 478). Apply a thread-locking agent to the screw threads during assembly.
- E. Place the intermediate housing (Item 447) onto the slide plate (Item 472 or 474) and then install the adjustable (Left-side) cam groove (Item 477).
- F. Install the socket head screws (Item 478) and the adjustment setscrews (Item 479). Apply a thread-locking agent to the screw threads during assembly. Do not completely tighten either set of screws – follow Steps 7 & 8!
- G. Adjust the cam groove set screws (Item 479) so that there is minimal side-play or side-movement and be certain that the friction drive housing (Item 447) can move freely.
- H. Then, tighten the socket head setscrews (Item 478).
- I. After completing the adjustment of the cam grooves (Item 477) the handwheel (Item 462) and handwheel assembly nut (Item 465) can be re-installed.
- J. Re-assemble the driving disc and re-connect the driving disc assembly and the driven disc assembly.



### IMPORTANT NOTE



The cam grooves or tapered gibs (Item 477) need to be adjusted during assembly.



# NORDISC™ ADJUSTABLE SPEED DRIVES



DRIVESYSTEMS

RETAIN FOR FUTURE USE

U21010 - 5 of 6

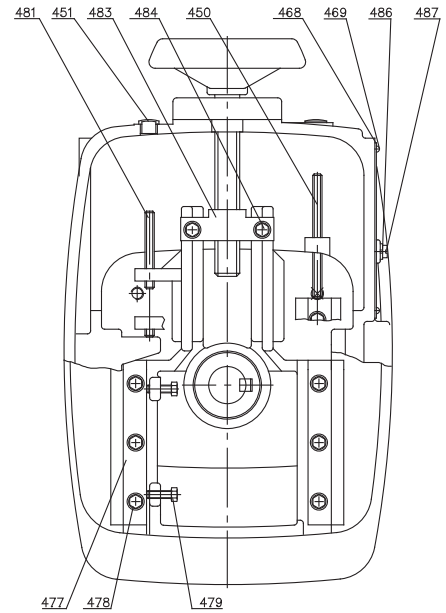
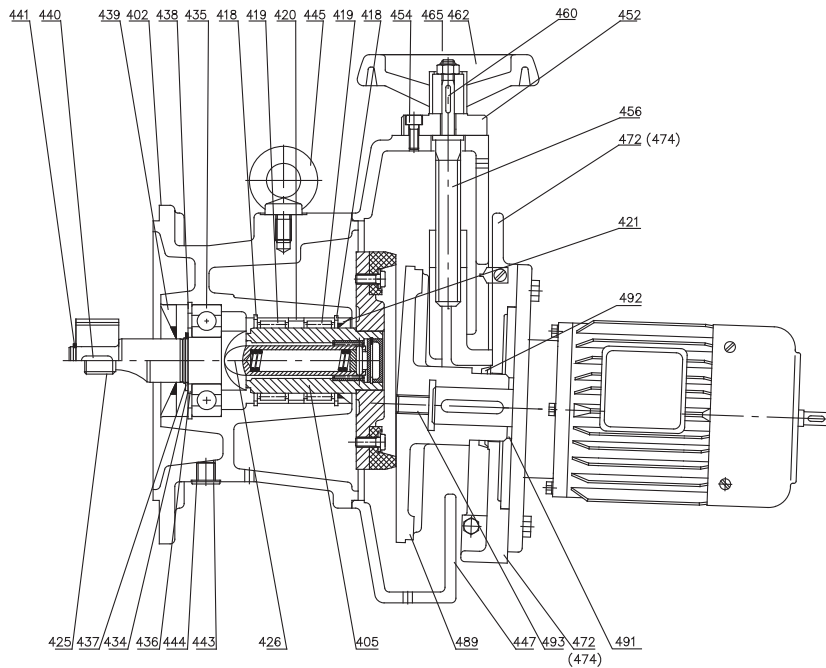

Item 426 (Shaft assembly) and Item 405 (Friction ring carrier assembly) are stocked as complete assemblies.  
Item 409 (Friction disc) can be ordered separately per the Table on page 6.

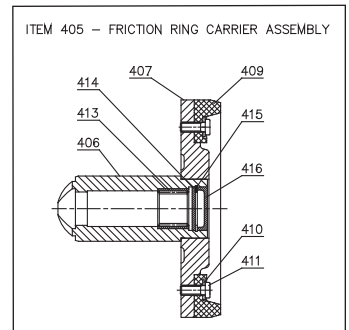
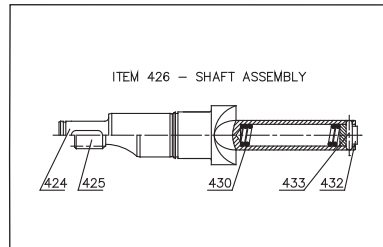

## NORDISC™ Parts List

402 Housing	456 Adjusting spindle	426 <b>Complete shaft assembly</b>
418 Snap Ring	460 Key	424 Shaft, plain cut *
419 Needle roller bearing	462 Hand wheel	425 Shaft, gear cut *
420 Spacer	464 Washer	430 Compression spring *
421 Seal	465 Hex nut	433 Dowel pin *
434 Shim	468 Scale	432 Spiral pin *
435 Ball Bearing	469 Rivet / self-tapping screw	
436 Supporting disc	472 Slide-plate (NEMA)	<b>* Included with Item 426</b>
437 Snap ring	474 Slide-plate (IEC)	
438 Snap ring	477 Cam groove / taper gib	405 <b>Friction ring carrier assy</b>
439 Seal	478 Socket head screw	406 Hollow shaft **
440 Key	479 Screw	407 Friction ring carrier **
441 Snap ring	481 Set screw	409 Friction disc **
443 Oil plug	483 Spindle nut	410 Socket head screw **
444 Gasket	484 Socket head screw	411 Washer **
445 Flanged eye bolt	486 Indicator	413 Needle roller bearing **
447 Intermediate housing	487 Indicator screw	414 Washer **
450 Set screw	489 Driving disc	415 Snap ring **
451 Bore plug	491 Supporting disc	416 Bore plug **
452 Spindle cover	492 V-ring seal	
454 Socket head screw	493 Set screw	<b>** Included with Item 405</b>
455 Snap ring		

**NORD Gear Limited**  
Toll Free in Canada: 800.668.4378

**NORD Gear Corporation**  
Toll Free in the United States: 888.314.6673



# NORDISC™ ADJUSTABLE SPEED DRIVES



DRIVESYSTEMS

RETAIN FOR FUTURE USE

U21010 - 6 of 6

## 8. NORDISC™ FRICTION DISC REPLACEMENT PART NUMBERS

NORDISC™ Type	RV10	RV20	RV30	RV40
Item 409 - Friction Disc Part Number	79119000	79219000	79319000	79419000

## 9. TROUBLESHOOTING

Problem With Variable Speed Unit	Possible Causes	Suggested Remedy
Drive Slips.	Friction Disc is worn. Friction Disc or Drive Disc face is dirty or contaminated. Load is too high.	Replace Friction Disc (Page 3). Clean Contaminated part: <ul style="list-style-type: none"> <li>• Friction Disc – use dry cloth or paper.</li> <li>• Drive Disc – okay to use mild solvent provided excess is removed or cleaned with a dry cloth. Check measured power and reduce operating load to catalog values.</li> </ul>
Drive heats up excessively.	Load is too high.	Check measured power and reduce operating load to catalog values.
Drive appears noisy or too loud.	Friction Disc is damaged: <ul style="list-style-type: none"> <li>• May be caused after a brief stalling of the drive.</li> <li>• May be caused by intermittent loading of the drive.</li> </ul>	Determine cause of damage, and replace friction disc (Page 3).
Adjust rate is too low.	Sluggish adjustment rate may be due to corrosion between the slide plate and the cam grooves that are internal to the intermediate housing.	Re-establish low-friction conduction. <ul style="list-style-type: none"> <li>• Separate driven disc assembly from driving disc assembly.</li> <li>• Clean and re-lubricate slide plate and cam grooves by applying a molybdenum-based anti-seize compound to these surfaces.</li> <li>• In extreme instances it may be necessary to remove the motor and cam grooves in order to thoroughly clean the cam grooves and slide plate.</li> </ul> Reference instructions on Page 4, “Cam Groove or Tapered Gib Adjustment”.